

4-Line Low Capacitance TVS Diode Array

Features

- IEC 61000-4-2 (ESD) $\pm 30\text{kV}$ (air), $\pm 30\text{kV}$ (contact)
- IEC 61000-4-4 (EFT) 40A (5/50ns)
- IEC 61000-4-5 (Lightning) 25A (8/20 μs)
- Low Capacitance: 1.5pF typical (I/O to I/O)
- Low leakage current
- Operating Voltage: 5V
- Low clamping Voltage
- Up to four data lines and one power line protects

Applications

- USB 2.0 Power and Data lines protection
- Digital Visual Interface (DVI)
- Monitors and Flat Panel Displays
- Video Graphic Cards
- Notebook and PC Computers

Mechanical Characteristics

- Package: SOT-23-6L
- Lead Finish: Matte Tin
- Case Material: "Green" Molding Compound.
- Moisture Sensitivity: Level 3 per J-STD-020
- RoHS Compliant

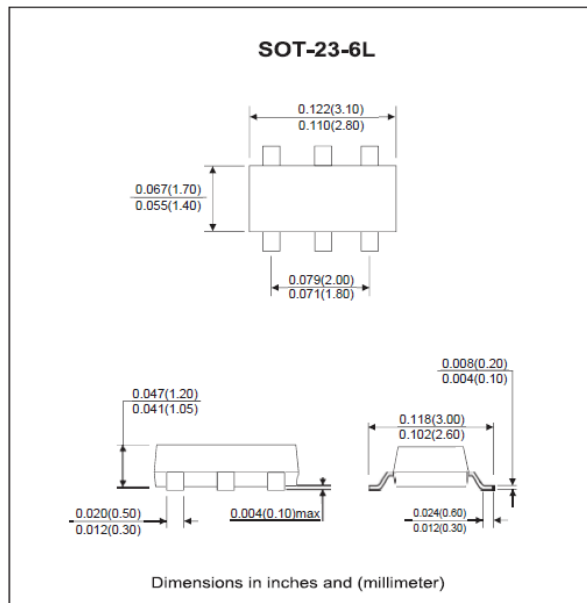

Circuit and Pin Schematic

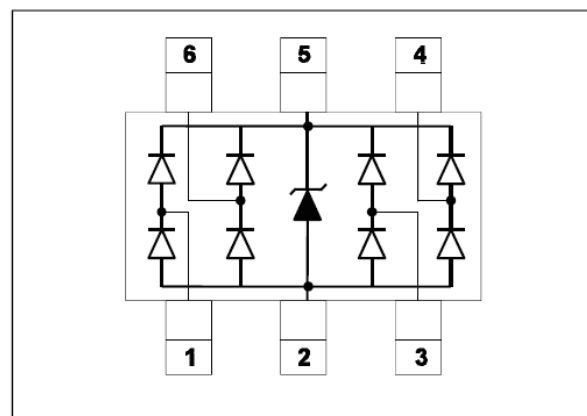

Absolute Maximum Ratings ($T_A = 25^\circ\text{C}$ Unless otherwise noted)			
Parameter	Symbol	Value	Unit
Peak Pulse Power ($t_p = 8/20\mu\text{s}$)	P_{PP}	500	W
Peak Pulse Current ($t_p = 8/20\mu\text{s}$)	I_{PP}	25	A
ESD per IEC 61000-4-2 (Air)	V_{ESD}	± 30	KV
ESD per IEC 61000-4-2 (Contact)		± 30	
Operating Temperature Range	T_J	-55 to + 125	$^\circ\text{C}$
Storage Temperature Range	T_{STG}	-55 to + 150	$^\circ\text{C}$

Electrical Parameters ($T_A = 25^\circ\text{C}$ Unless otherwise noted)	
Symbol	Parameter
I_{PP}	Reverse Peak Pulse Current
V_C	Clamping Voltage @ I_{PP}
V_{RWM}	Reverse Stand-Off Voltage
I_R	Reverse Leakage Current @ V_{RWM}
V_{BR}	Breakdown Voltage @ I_T
I_T	Test Current
I_F	Forward Current
V_F	Forward Voltage @ I_F

Electrical Characteristics ($T_A = 25^\circ\text{C}$ Unless otherwise noted)						
Parameter	Symbol	Test Conditions	Min.	Typ.	Max.	Units
Reverse Standoff Voltage	V_{RWM}	Any I/O pin to ground			5	V
Reverse breakdown Voltage	V_{BR}	$I_T = 1\text{mA}$, Any I/O pin to ground	6			V
Reverse leakage current	I_R	$V_{RWM} = 5\text{V}$, Any I/O pin to ground			1	μA
Clamping Voltage	V_C	$I_{PP} = 1\text{A}$ ($t_p = 8/20\mu\text{s}$), any I/O pin to ground			12	V
Clamping Voltage	V_C	$I_{PP} = 25\text{A}$ ($t_p = 8/20\mu\text{s}$), any I/O pin to ground			20	V
Junction capacitance	C_J	$V_R = 0\text{V}$, $f = 1\text{MHz}$, between I/O pins		1.5		pF
Junction capacitance	C_J	$V_R = 0\text{V}$, $f = 1\text{MHz}$, any I/O pin to ground		3.0	5.0	pF

Note 1: I/O pins are Pin 1, 3, 4 and 6

Typical Performance Characteristics ($T_A = 25^\circ\text{C}$ Unless otherwise noted)

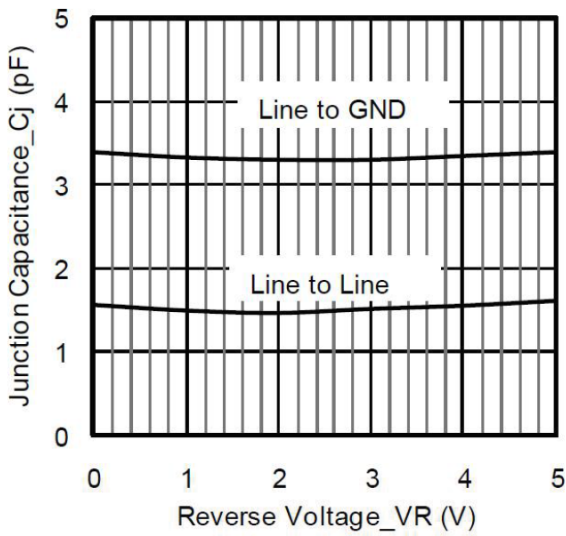

Figure 1. Junction Capacitance vs. Reverse Voltage

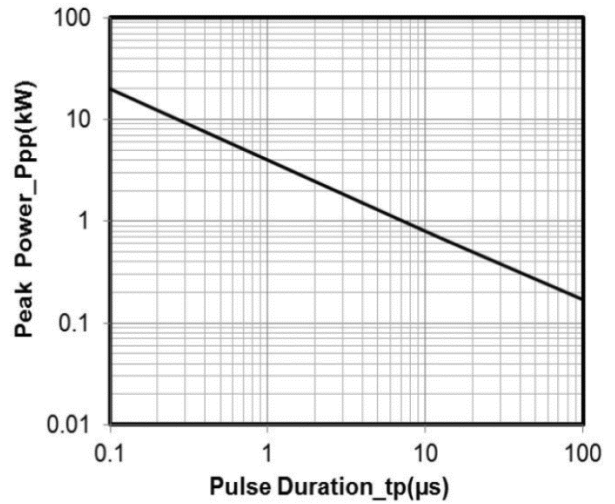

Figure 2. Peak Pulse Power vs. Pulse Time

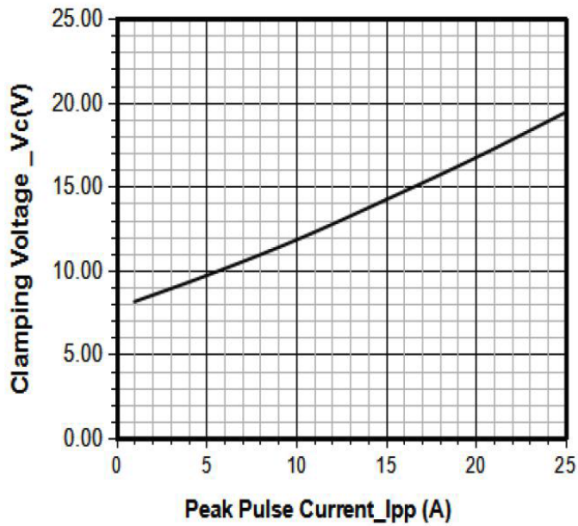

Figure 3. Clamping Voltage vs. Peak Pulse Current

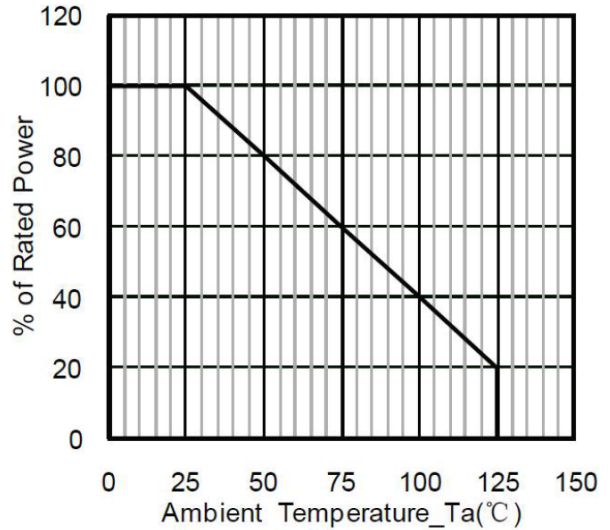

Figure 4. Power Derating Curve

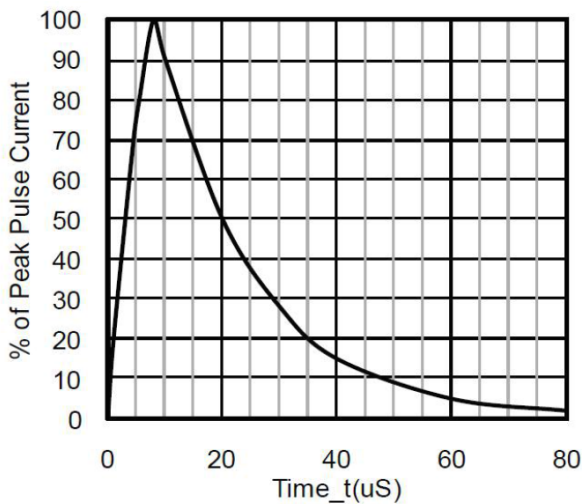

Figure 5. 8 X 20μs Pulse Waveform

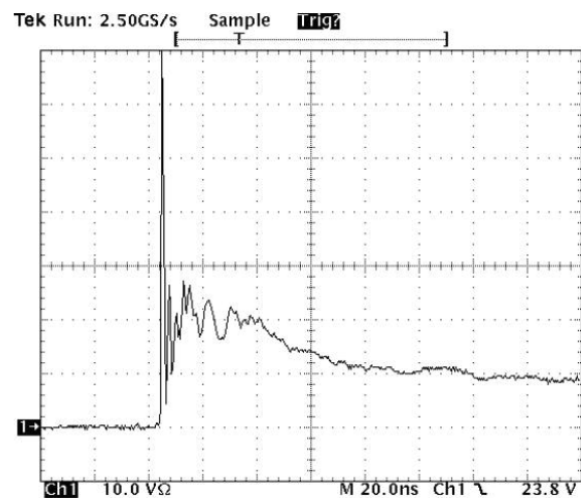
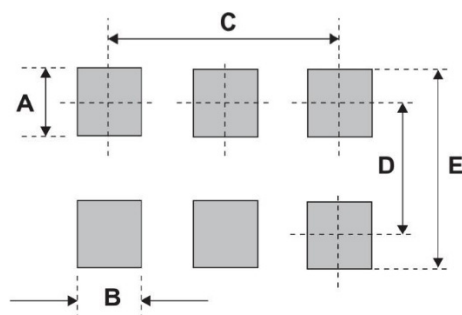

Figure 6. ESD Clamping Voltage
8 KV Contact per IEC61000-4-2

Suggested PAD Layout

Symbol	SOT-23-6L	
	(mm)	(inch)
A	1.10	0.043
B	0.60	0.024
C	1.90	0.075
D	2.50	0.098
E	3.60	0.142



The diagram shows a top-down view of the SOT-23-6L package pad layout. It features six square pads arranged in two rows of three. Dimension A is the height of the top row of pads. Dimension B is the width of the pads in the bottom row. Dimension C is the distance between the centers of the pads in the top row. Dimension D is the distance between the center of the first pad in the top row and the center of the first pad in the bottom row. Dimension E is the total height of the pad layout, including the distance between the top and bottom rows of pads.

Marking Code

Part Number	Marking Code
SC05Y4UTS	SRV05
SRV05 = Device Marking Code	

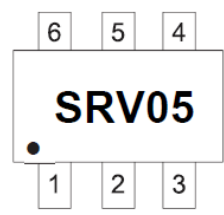

The diagram shows a rectangular marking area on a package. The code 'SRV05' is printed in the center. Above the code are three small boxes containing the numbers 6, 5, and 4. Below the code are three small boxes containing the numbers 1, 2, and 3. A small black dot is located to the left of the 'R' in 'SRV05'.

Ordering information

Part Number	Package	Base qty	Reel Size	Delivery mode
		(pcs)	(inch)	
SC05Y4UTS	SOT-23-6L	3,000	7	Tape and reel