

### Gas Discharge Tubes(GDT)



#### Description

Gas discharge tubes (GDT) use noble gasses enclosed in ceramic tubes to provide an alternate circuit path for voltage spikes. The ceramic envelope and with nickel connectors allow for high loads.

3RA-5SS Gas Discharge Tubes (GDT) series has a surge rating of 5kA, 8/20 $\mu$ s. Offered in a Squared Surface Mount package, which helps to make pick and place on PCB process easier.

This GDT series is perfectly suited for broadband equipment applications. The GDT's low off-state capacitance is compatible with high bandwidth applications and this capacitance loading value does not vary if the voltage across the GDT changes.

3RA-5SS Gas Discharge Tube (GDT) series are specifically designed for protection of electrical, multimedia, and communication equipment against over voltage transients in surface mount assembly applications.

#### Electrical symbol

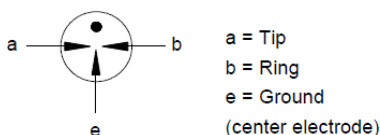

#### Features

- ◆ Excellent response to fast rising transients
- ◆ Stable breakdown voltage
- ◆ GHz working frequency
- ◆ 8/20 $\mu$ s Impulse current capability: 5KA
- ◆ Surface Mount package
- ◆ Non-Radioactive
- ◆ Ultra Low capacitance(<1pF)
- ◆ High insulation resistance
- ◆ Lead-free and RoHS compliant
- ◆ Size: 5mm\*5mm\*7.5mm
- ◆ Storage and operational temperature: -40~+90°C

#### Applications

- ◆ Communication equipment
- ◆ CATV equipment
- ◆ Test equipment
- ◆ Data lines
- ◆ Power supplies
- ◆ Telecom SLIC protection
- ◆ Medical Electronics
- ◆ ADSL equipment, including ADSL2+
- ◆ XDSL equipment
- ◆ Satellite and CATV equipment

#### Part Number Code

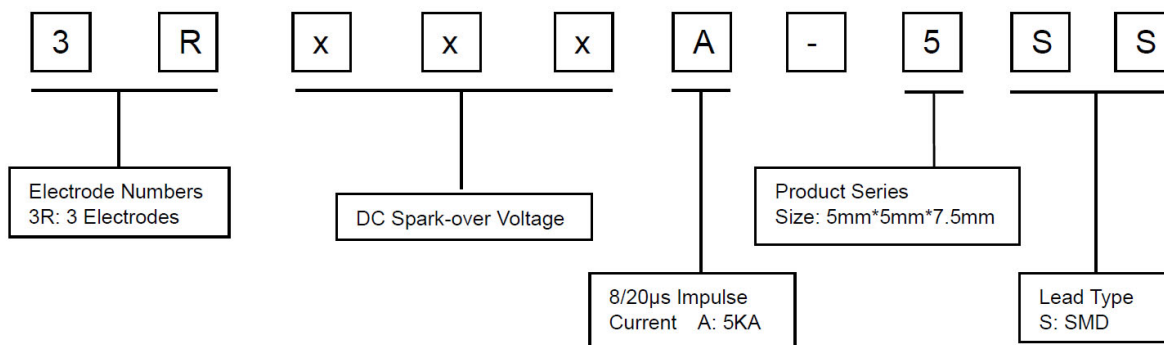

### Gas Discharge Tubes(GDT)

#### Electrical Characteristics

Terms in accordance with ITU-T Rec. K.12, IEC 61643-311, GB/T 9043.

Part Number	DC Spark-over Voltage <sup>1) 2) 3)</sup> @100V/S	Impulse Spark-over Voltage <sup>3)</sup>		Insulation Resistance <sup>4)</sup>	Capacitance @1 MHz	Life Ratings				
		100V/ $\mu$ S	1KV/ $\mu$ S			Impulse Discharge Current @8/20 $\mu$ S <sup>5)</sup>		Impulse Life @10/1000 $\mu$ S 200A <sup>5)</sup>		
		Max	Max			Min	Max	Nominal $\pm$ 5 times	Max 1 time	Min
		V	V			V	G $\Omega$	pF	KA	KA
3R075A-5SS	75 $\pm$ 20%	500	600	1	1	5	10	100		
3R090A-5SS	90 $\pm$ 20%	500	600	1	1	5	10	100		
3R150A-5SS	150 $\pm$ 20%	500	600	1	1	5	10	100		
3R200A-5SS	200 $\pm$ 20%	600	700	1	1	5	10	100		
3R230A-5SS	230 $\pm$ 20%	600	700	1	1	5	10	100		
3R250A-5SS	250 $\pm$ 20%	600	700	1	1	5	10	100		
3R350A-5SS	350 $\pm$ 20%	800	900	1	1	5	10	100		
3R400A-5SS	400 $\pm$ 20%	850	950	1	1	5	10	100		
3R420A-5SS	420 $\pm$ 20%	850	950	1	1	5	10	100		
3R470A-5SS	470 $\pm$ 20%	900	1000	1	1	5	10	100		
3R600A-5SS	600 $\pm$ 20%	1100	1200	1	1	5	10	100		
3R800A-5SS	800 $\pm$ 20%	1400	1500	1	1	5	10	100		

Glow Voltage at 10mA..... ~60V  
 Arc Voltage at 1A..... ~10V  
 Glow to Arc transition Current..... ~0.5A  
 Operation and storage temperature..... -40~+90°C  
 Climatic category (IEC 60068-1)..... 40/90/21  
 Marking..... Without

Notes :

- 1) At delivery AQL 0.65 level II, DIN ISO 2859
- 2) In ionized mode
- 3) Tip or ring electrode to center electrode
- 4) Insulation Resistance Measuring Voltage :
  - 75V at DC 25V
  - 90V~150V at DC 50V
  - Other at DC 100V
- 5) Total current through center electrode, half value through tip respectively ring electrode.

### Gas Discharge Tubes(GDT)

#### Dimensions

Symbol	Millimeters	Inches
A	5.0±0.2	0.197±0.008
B	5.0±0.2	0.197±0.008
C	7.5±0.3	0.295±0.012
D	1.5±0.1	0.059±0.004
E	0.5±0.1	0.020±0.004
F	0.5±0.1	0.020±0.004

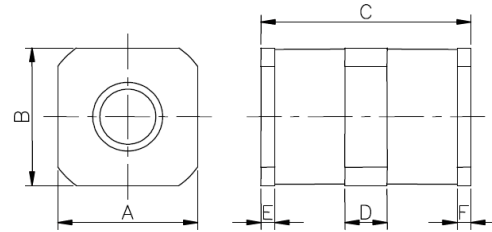

#### Recommended Pad Layout

Symbol	Millimeters	Inches
X	1.6	0.063
X1	2.8	0.110
X2	7.4	0.291
Y	5.0	0.197

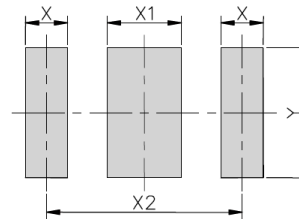

#### Taping and Reel Specifications

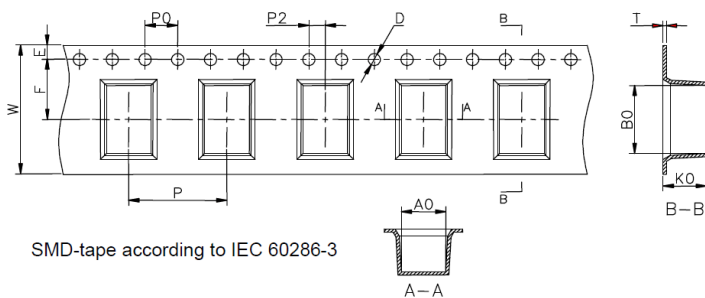

SMD-tape according to IEC 60286-3

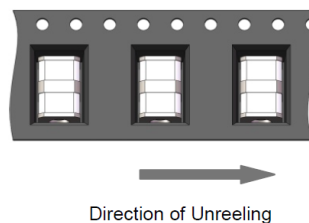
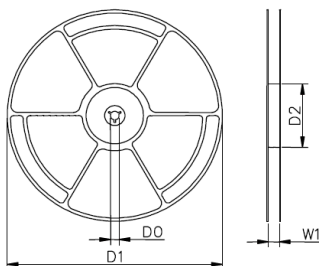

Symbol	Millimeters	Inches
W	16±0.3	0.630±0.012
A0	5.4±0.1	0.213±0.004
B0	8.4±0.1	0.331±0.004
K0	5.3±0.1	0.209±0.004
P	12±0.1	0.472±0.004
F	7.5±0.1	0.295±0.004
E	1.75±0.1	0.069±0.004
D	1.5+0.1/-0.0	0.059+0.004/-0.0
P0	4±0.1	0.157±0.004
P2	2±0.1	0.079±0.004
T	0.4±0.1	0.016±0.004
D0	13.3±0.15	0.524±0.006
D1	330±2	12.992±0.079
D2	100+1/-2	3.937+0.039/-0.079
W1	16.5±0.4	0.65±0.016

### Gas Discharge Tubes(GDT)

#### Packaging Quantity

- 1,000 PCS per reel (13")
- 3 reels per inner box
- 3,000 PCS per inner box

#### Soldering Parameters - Reflow Soldering (Surface Mount Devices)

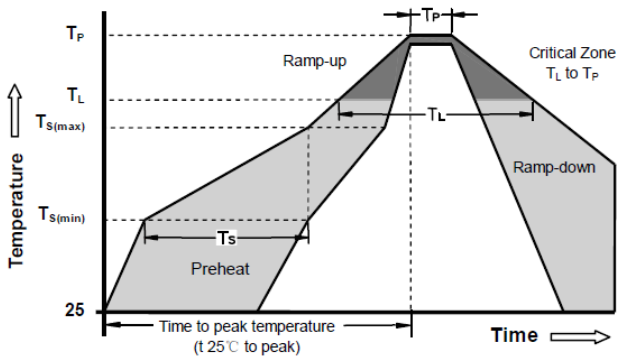

Reflow Condition		Pb - Free assembly
Pre Heat	-Temperature Min ( $T_{S(min)}$ )	150°C
	-Temperature Max ( $T_{S(max)}$ )	200°C
	-Time (min to max) ( $t_s$ )	60 -180 Seconds
Average ramp up rate ( Liquids Temp $T_L$ to peak)		3°C/second max
$T_{S(max)}$ to $T_L$ - Ramp-up Rate		5°C/second max
Reflow	- Temperature ( $T_L$ ) (Liquids)	217°C
	- Time (min to max) ( $t_s$ )	60 -150 Seconds
Peak Temperature ( $T_P$ )		260 +0/-5°C
Time within 5°C of actual peak Temperature ( $t_p$ )		10 - 30 Seconds
Ramp-down Rate		6°C/second max
Time 25°C to peak Temperature ( $T_P$ )		8 minutes Max
Do not exceed		260°C