

SURFACE MOUNT SCHOTTKY BARRIER RECTIFIERS

REVERSE VOLTAGE: 20 to 200 VOLTS

FORWARD CURRENT: 1.0 AMPERE

Features

- Plastic package has Underwriters Laboratory Flammability Classification 94V-O
- Metal silicon junction, majority carrier conduction
- Low power loss, high efficiency
- For surface mounted applications
- High current capability, Low forward voltage drop
- High temperature soldering guaranteed:
260°C/10 seconds at terminals
- Component in accordance to RoHS 2015/863/EU

Mechanical Data

- Case: JEDEC SMA(DO-214AC)
- Terminals: Solder plated, solderable per MIL-STD-750, method 2026 guaranteed
- Tape Reel: 5000pcs

SMA(DO-214AC)

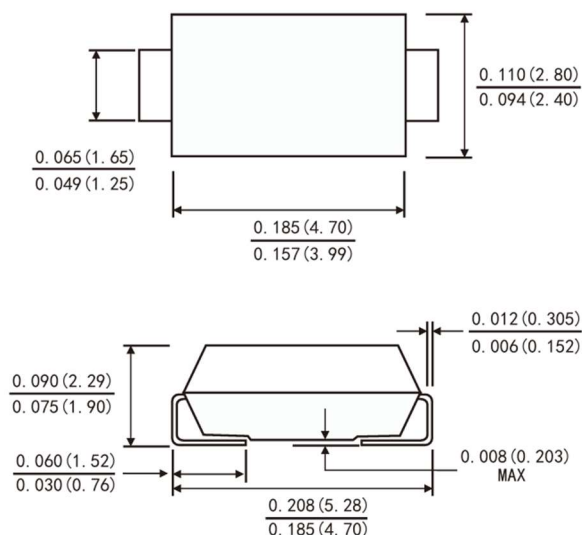

Dimensions in inches and (millimeters)

Maximum Ratings and Electrical Characteristics

Ratings at 25°C ambient temperature unless otherwise specified. Single phase, half wave, 60HZ, resistive or inductive load.

For capacitive load, derate current by 20%.

Parameters / Marking Code	Symbols	SS12	SS13	SS14	SS16	SS110	SS115	SS120	Units
Maximum repetitive peak reverse voltage	V _{RRM}	20	30	40	60	100	150	200	Volts
Maximum RMS voltage	V _{RMS}	14	21	28	42	71	105	140	Volts
Maximum DC blocking voltage	V _{DC}	20	30	40	60	100	150	200	Volts
Maximum average forward rectified current 0.375"(9.5mm) lead length(see Fig. 1)	I(AV)	1.0							Amp
Peak forward surge current 8.3ms single half sine-wave superimposed on rated load (JEDEC method)	I _{FSM}	40.0							Amps
Maximum instantaneous forward voltage at 1.0 A(Note 1)	V _F	0.55		0.70		0.85	0.90	0.95	Volts
Maximum instantaneous reverse current at rated DC blocking voltage(Note 1)	T _J =25°C	100				20			μA
	T _J =100°C	5				-			mA
	T _J =125°C	-				3			
Typical junction capacitance(Note 3)	C _J	40				20			PF
Typical thermal resistance(Note 2)	R _{θJA} R _{θJL}	88.0 28.0							°C/W
Operating junction temperature range	T _J	-55 to+150							°C
Storage temperature range	T _{STG}	-55 to+150							°C

NOTES:

1. Pulse test: 300μs pulse width, 1% duty cycle
2. P.C.B. mounted with 0.2 X 0.2"(5.0 X 5.0mm) copper pad areas
3. Measured at 1MHZ and reverse voltage of 4.0 volts

RATINGS AND CHARACTERISTIC CURVES

FIG.1-FORWARD CURRENT DERATING CURVE

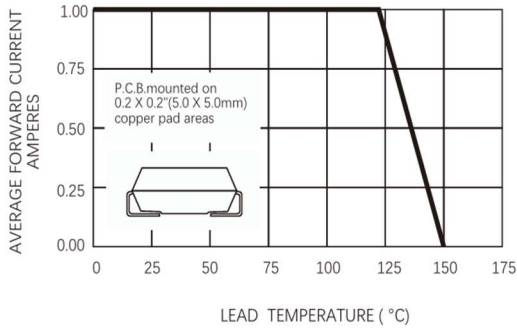

FIG.2-MAXIMUM NON-REPETITIVE PEAK FORWARD SURGE CURRENT

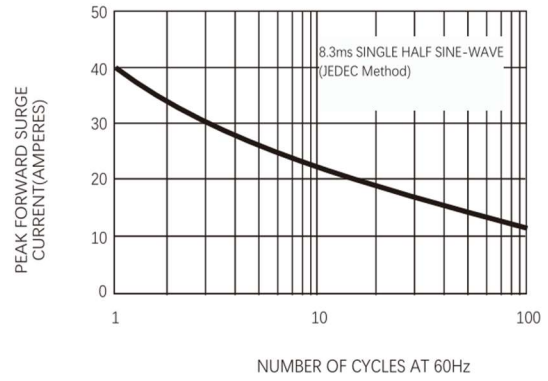

FIG.3-TYPICAL INSTANTANEOUS FORWARD CHARACTERISTICS

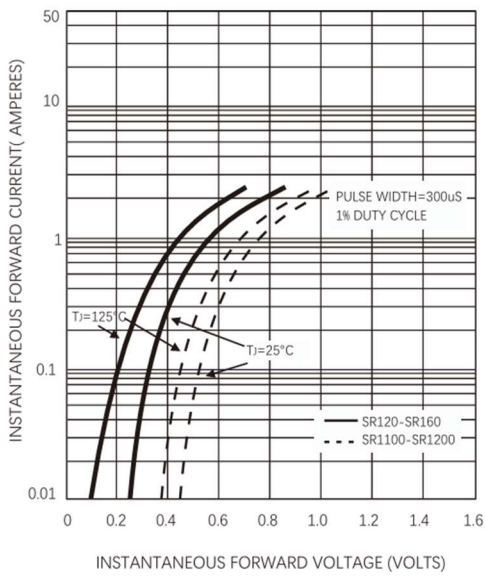

FIG.4-TYPICAL REVERSE CHARACTERISTICS

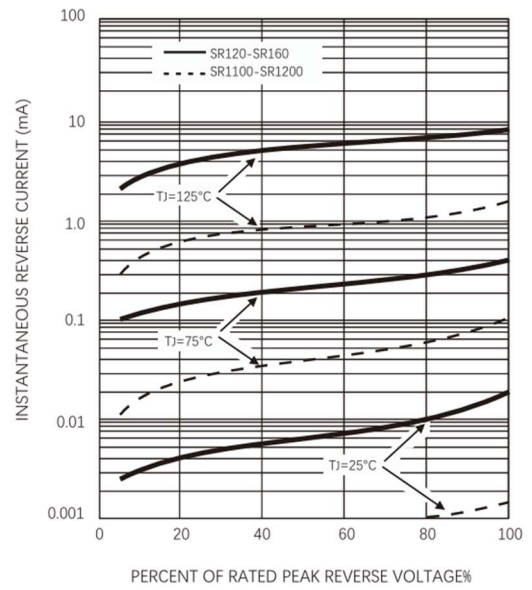

FIG.5-TYPICAL JUNCTION CAPACITANCE

